

# 1060 Series

SNAP TELESCOPING EASEL

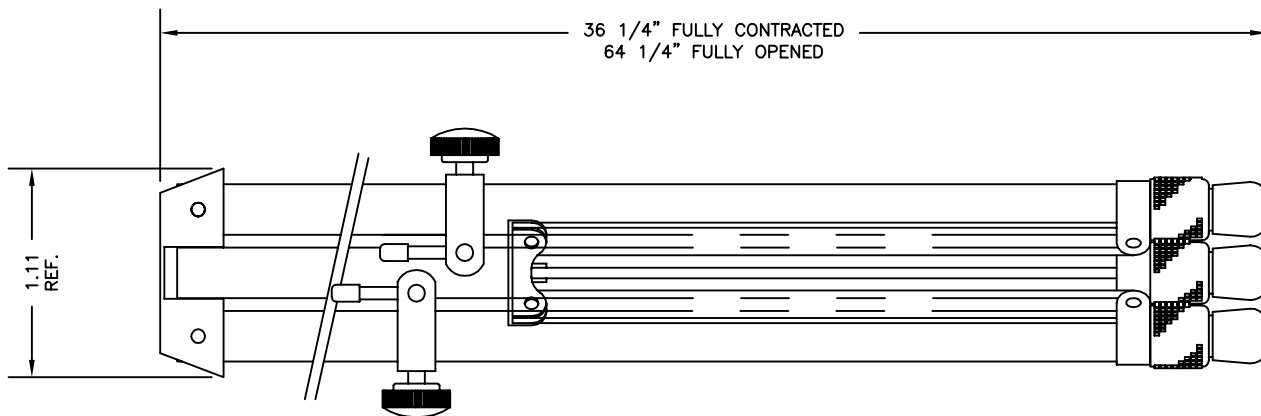

## Specifications

All exposed metal shall be satin anodized aluminum 6063-T5. When unit is fully extended the width of the unit is 3 feet. The 1060 Telescoping Easel has two adjustable holders. The legs of the unit have rubber stoppers on them to keep them from skidding. There is a tri-connector that adds stability when legs are extended. The 1060 unit can be use on top of a table when the legs are fully contracted, or on the floor when legs are fully opened.