

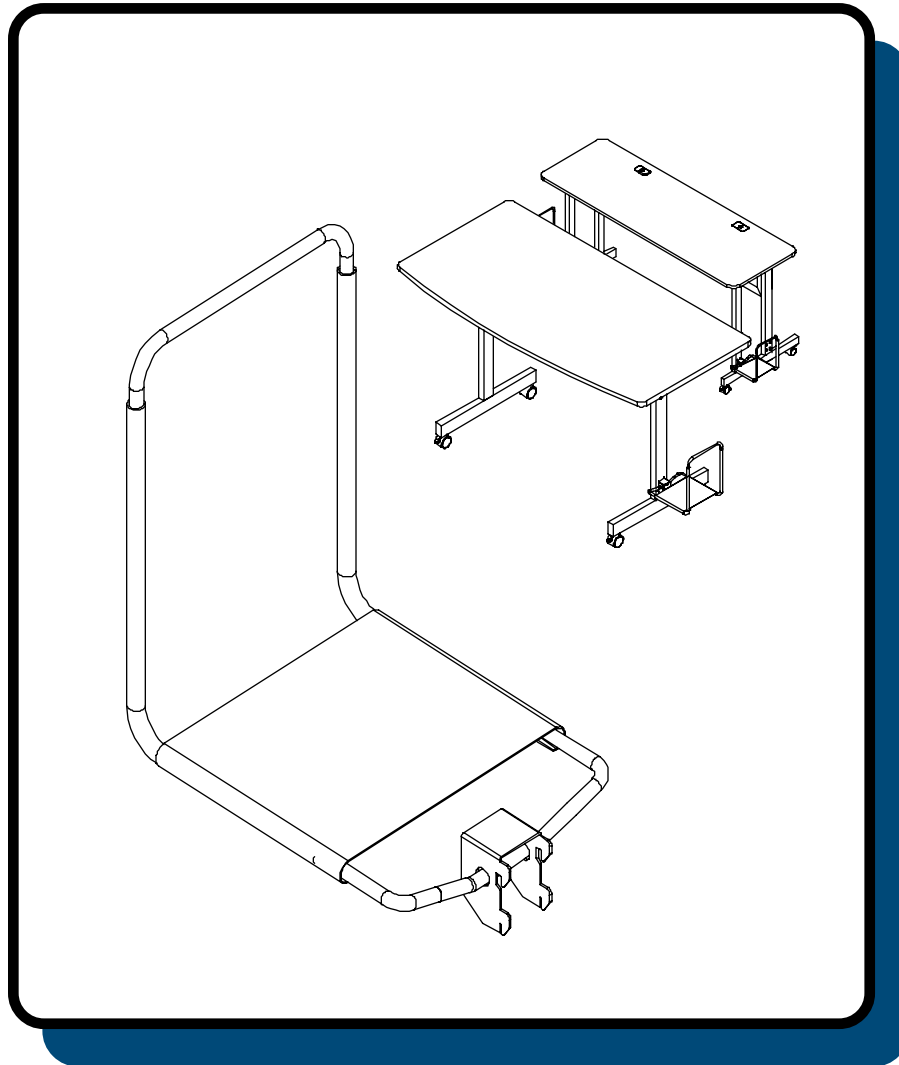

BLT-34412

Adjustable CPU Holder



Assembly Instructions

BLT-34412

Adjustable CPU Holder

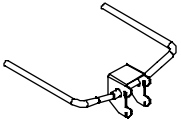
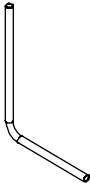
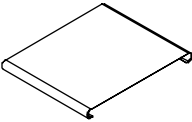
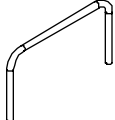
Part	Drawing	Description	Qty	Part	Drawing	Description	Qty
P1		Welded Base	1 EA	P3		CPU Support Tubes	2 EA
P2		Metal CPU Platform	1 EA	P4		CPU Rail	1 EA

1. Identify and Separate all the Parts and Hardware.

Illustration # 1

2. Slide CPU Support Tubes (P-3) into Metal CPU Platform (P-2). Insert Welded Base (P-1) into CPU Support Tubes (P-3) as shown in illustration #1.

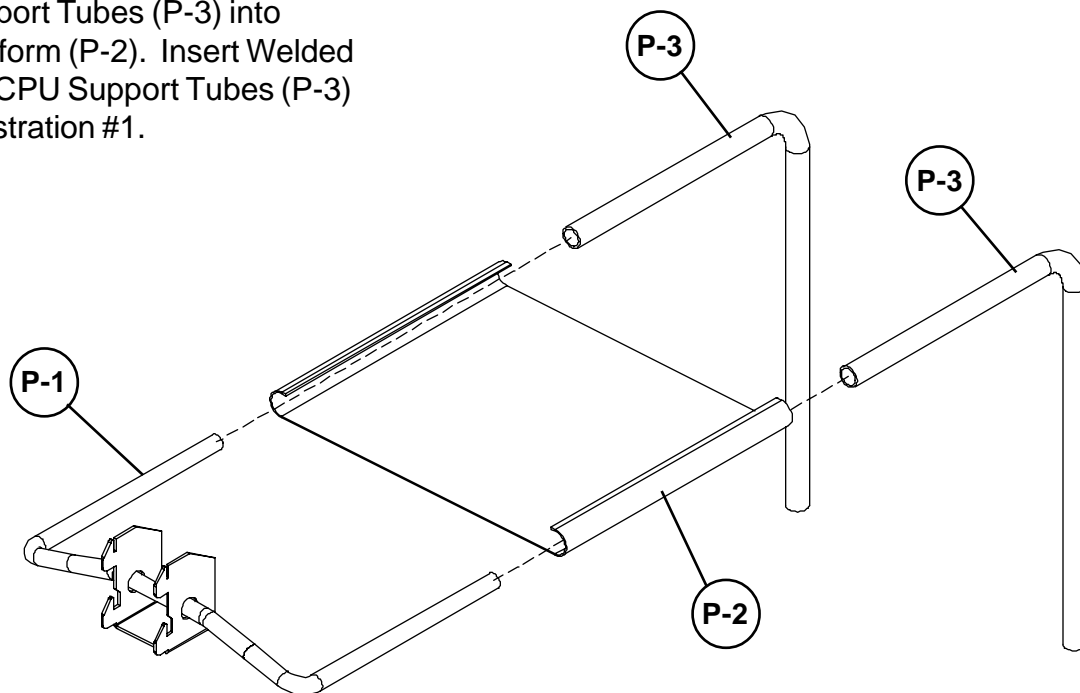

Missing Parts or UPS Damaged Parts

For Your Convenience you can
EMAIL us at

info@ergoindemand.com

24HOURS 7 DAYS A WEEK

***Should you require assistance during assembly,
please call our Customer Service Department***

Monday - Friday 8 a.m. - 4.30 p.m.

Pacific Time 1-800-888-6024

Do not use unless all screws are tight. At least every six months, check all screws to be sure they are tight. If parts are missing, broken, damaged, or worn, stop use of the product until repairs are made by your dealer using factory authorized parts.

BLT-34412 Assembly Diagram

Illustration # 2

3. Slide CPU Rail (P-4) into CPU Support Tubes (P-3).

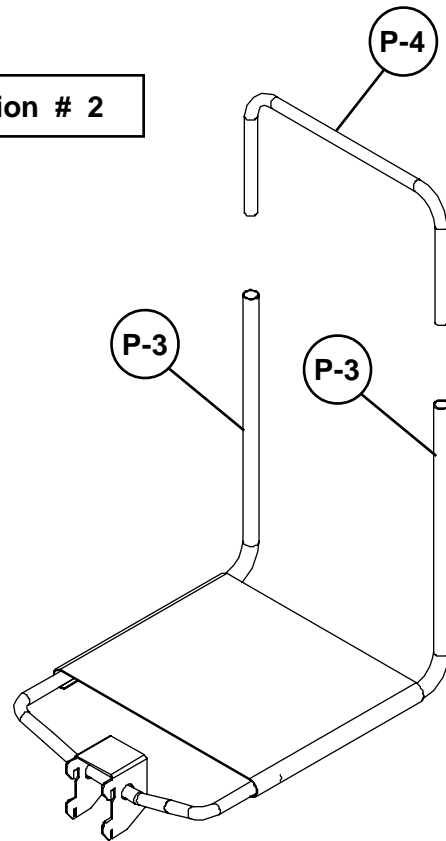
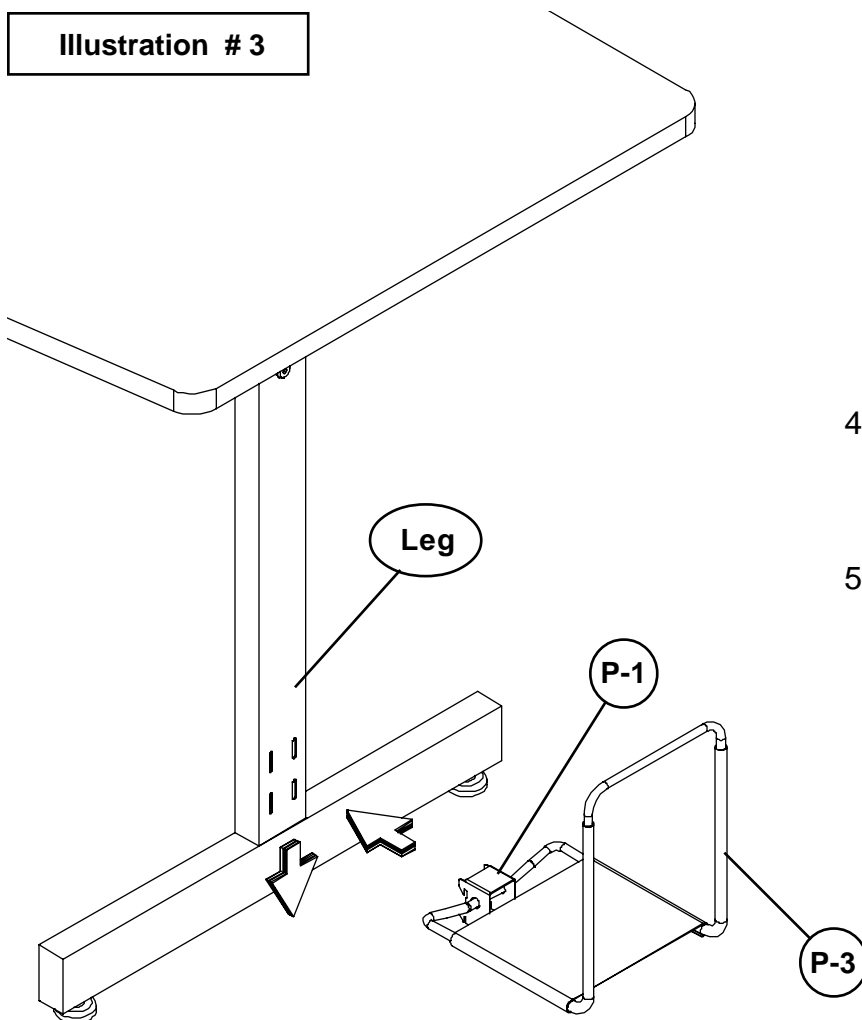

Illustration # 3



4. Insert Welded Base (P-1) into the Slots in Leg and press down as shown in illustration #3.

5. Adjust Width of CPU Holder by pulling out, or pushing in the CPU Support Tubes (P-3).